

Strap footing design

- ◆ [Introduction](#)
- ◆ [Service load design](#)
- ◆ [Example 3.4. Determine sizes of strap footing](#)
- ◆ [Structural analysis of strap footing](#)
- ◆ [Example 3.5: Determine moment and shear in a strap footing](#)
- ◆ [Reinforced concrete design of strap footing](#)
- ◆ [Example 3.6 Reinforced concrete design of a strap footing](#)

Introduction

Combined footings and strap footings are normally used when one of the columns is subjected to large eccentric loadings. When two columns are reasonably close, a combined footing is designed for both columns as shown in Figure 3.1. When two columns are far apart, a strap is designed to transfer eccentric moment between two columns as shown in Figure 3.1. The goal is to have uniform bearing pressure and to minimize differential settlement between columns.

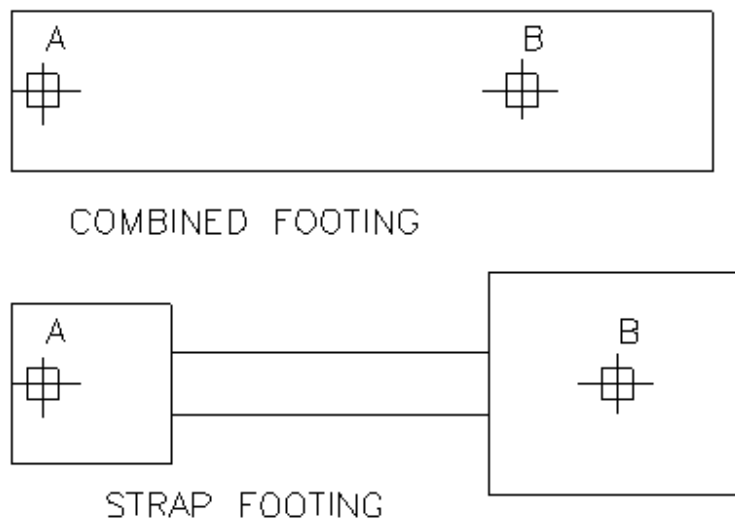
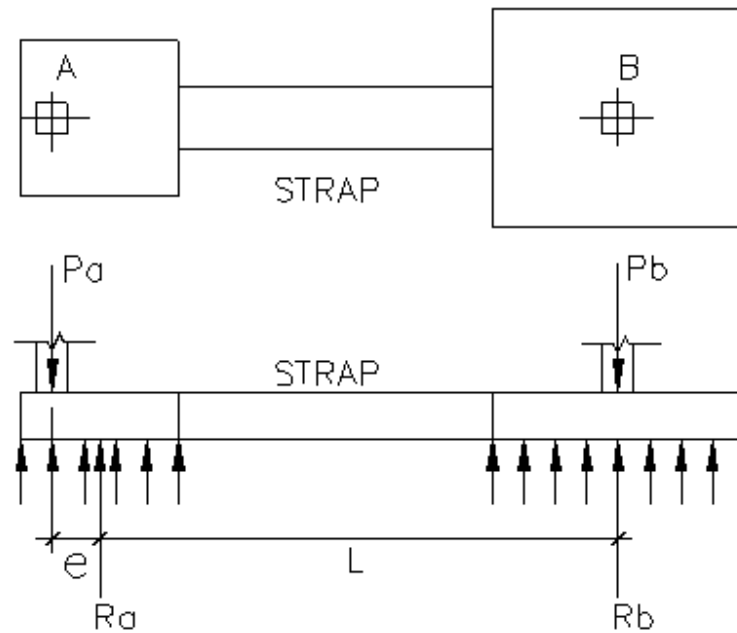

Figure 3.1 Combined footing and strap footing



Design assumptions

1. Strap does not provide bearing.
2. Strap is rigid enough to transfer moment from one footing to the other.

Design procedure

Service load design:

1. Determine the length of exterior footing and its eccentricity, e .
2. Determine eccentric moment, $M = P_a * e$.
3. Determine shear force, $V = M / L$
4. Determine footing reaction, $R_a = P_a + V$, and $R_b = P_b - V$
5. Determine footing sizes for both A & B.

Structural analysis

1. Calculate factored column loads, P_{ua} & P_{ub}
2. Calculate factored eccentric moment $M_u = P_{ua} * e$
3. Calculate factored shear, $V_u = M_u / L$
4. Determine factored reactions, R_{ua} & R_{ub} .
5. Perform structural analysis, determine factored shear and moment on footings and strap.

Reinforced concrete design

1. Design exterior footing. Check shear stresses and design flexural reinforcement.
2. Design interior footing. Check shear stresses and design flexural reinforcements.
3. Design footing strap as a reinforced concrete beam.

Service load design:

Design procedure:

1. Determine the length of exterior footing and its eccentricity, e .
2. Determine eccentric moment, $M = P_a * e$.
3. Determine shear force, $V = M / L$
4. Determine footing reaction, $R_a = P_a + V$, and $R_b = P_b - V$
5. Determine footing sizes for both A & B.

Example 3.4. Determine sizes of strap footing

Given:

- ◆ Column information:
- ◆ Column A: Live load = 40 kips, Dead load = 50 kips
- ◆ Column B: Live load = 80 kips, Dead load = 100 kips.
- ◆ Distance between two columns: 22 ft.
- ◆ Footing information:
- ◆ Allowable soil bearing capacity; 3000 psf
- ◆ Distance from column A to edge of footing: 1 ft.
- ◆ Allowable soil bearing capacity = 3000 psf
- ◆ Weight of soil above footing = 120 psf
- ◆ Depth of footing = 24"
- ◆ Depth of soil above footing = 12"

Requirements: Determine the size of footing A & B.

Solution:

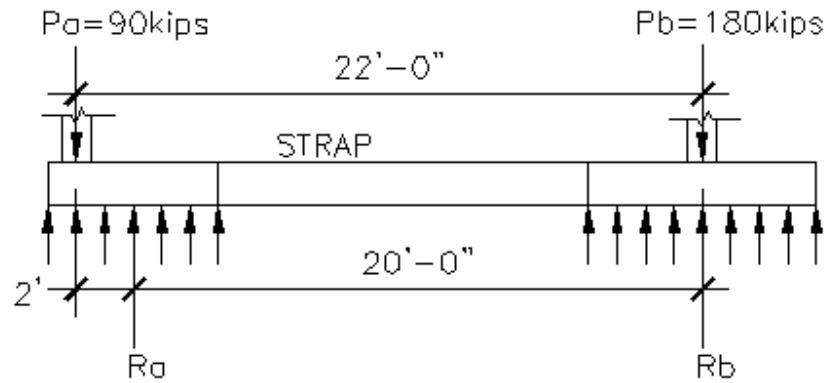

Assume a footing width of 6 ft, the eccentricity of footing A is $e = 6/2 - 1 = 2'$.

The distance between footing reaction, $L = 22 - 2 = 20'$

The eccentric moment is $M = (40 + 50) * 2 = 180$ ft-kips

The shear produced by M is, $V = 180/20 = 9$ kips

Reaction at footing A = $40 + 50 + 9 = 99$ kips

Net soil bearing capacity = $3000 - 2 * 150 - 120 = 2580$ psf

Required footing area of A = $99/2.58 = 38.4$ ft².

Use 6' by 6.5' footing, area = 39 ft².

Reaction at footing B = $100 + 80 - 9 = 171$ kips

Required footing area = $171/2.58 = 66.3$ ft².

Use 8' by 8.5' footing, A = 68 ft².

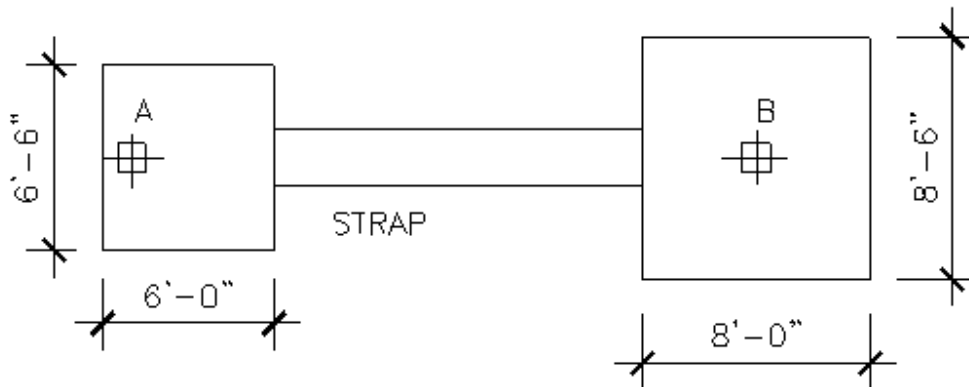

Structural analysis of strap footing

Procedures

1. Calculate factored column loads, P_{ua} & P_{ub}
2. Calculate factored eccentric moment $M_u = P_{ua} \cdot e$
3. Calculate factored shear, $V_u = M_u / L$
4. Determine factored reactions, R_{ua} & R_{ub} .
5. Determine factored footing reactions.
6. Perform structural analysis; determine factored shear and moment on footings and strap.

Example 3.5: Determine moment and shear in a strap footing

Given: The strap footing in example 3.4

Requirement: Determine maximum factored shears and moment in the footings and strap.

Solution:

Factored column load of A = $1.4 \cdot 50 + 1.7 \cdot 40 = 138$ kips

Factored column load of B = $1.4 \cdot 100 + 1.7 \cdot 80 = 276$ kips

Factored eccentric moment, $M_u = 138 \cdot 2 = 276$ ft-kips

Factored shear, $V_u = 276 / 20 = 13.8$ kips

Factored footing reaction at A = $138 + 13.8 = 151.8$ kips

Factored footing pressure per linear foot of A = $151.8 / 6 = 25.3$ k/ft

Factored footing reaction at B = $276 - 13.8 = 262.2$ kips

Factored footing pressure per linear foot at B = $262.2/8 = 32.8$ k/ft.

Shear diagram:

At point 1: $V_u = 25.3 * 1.5 - 138 = -100.1$ kips

At point 2: $V_u = 25.3 * 6 - 138 = 13.8$ kips

At point 3: $V_u = 25.3 * 6 - 138 = 13.8$ kips

At point 4: $V_u = 13.8 + 32.8 * 3.5 = 128.6$ kips

At point 5: $V_u = 32.8 * -3.5 = -114.8$ kips

Moment diagram:

At point 1: $M_u = 25.3 * 1.5^2/2 - 138 * 0.5 = -40.5$ ft-kips

At point 2: $M_u = 25.3 * 6^2/2 - 138 * 5 = -234.6$ ft-kips

At point 3: $M_u = 25.3 * 6 * (6/2 + 13) - 138 * (5 + 13) = -55.2$ ft-kips

At point 4: $M_u = 25.3 * 6 * (6/2 + 13 + 3.5) - 138 * (5 + 13 + 3.5) + 32.8 * 3.5^2/2 = 194$ ft-kips

At point 5: $M_u = 32.8 * 3.5^2/2 = 200.9$ ft-kips

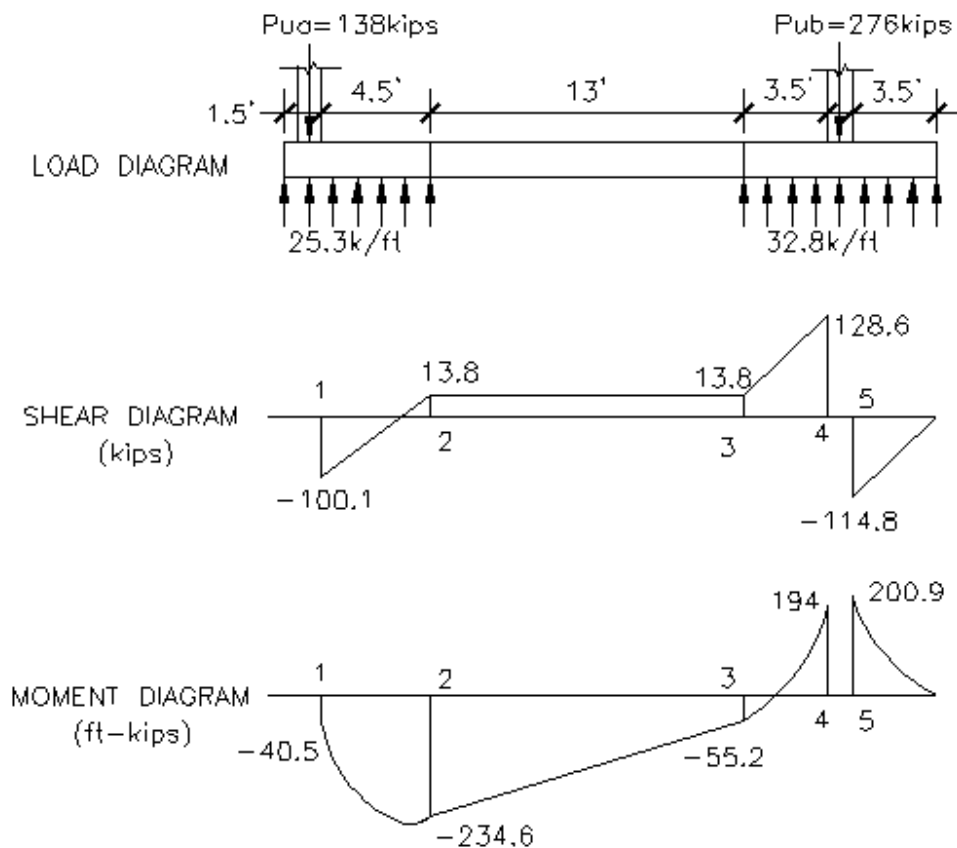

Reinforced concrete design of strap footing

Design procedure:

1. Design exterior footing. Check shear stresses and design flexural reinforcement.
2. Design interior footing. Check shear stresses and design flexural reinforcements.
3. Design footing strap as a reinforced concrete beam.

Example 3.6 Reinforced concrete design of a strap footing

Given:

- ◆ A strap footing with loading, shear, and moment as shown in example 3.4 & 3.5
- ◆ Compressive strength of concrete for footing at 28 days: 3000 psi
- ◆ Yield strength of rebars: 60 ksi

Requirement: design footing depth and flexural reinforcements.

Solution:

1. Design footing strap

Assume a 2'-6" by 2' footing strap and the reinforcement is #8 bars, with 2" top cover the effective depth, $d = 24 - 2 - 1 = 21$ "

a. Check direct shear

From Example 3.5, the factored shear force on footing strap, $V_u = 13.8$ kips

Factored shear strength of concrete,

$$\phi V_c = \phi v_c * b * d = (0.85 \times 2 \times 3000) * 30 * 21 / 1000 = 58.6 \text{ kips}$$

Minimum shear strength of concrete without shear reinforcement.

$$1/2 \phi V_c = 0.5 * 58.6 = 29.3 \text{ kips} > 13.8 \text{ kips no shear reinforcement is required}$$

b. Design flexural reinforcement

From Example 3.5, the maximum factored moment at point 1, $M_u = 234.6$ ft-kips

Use trail method for reinforcement design

Assume $a = 1.6$ ".

$$T = \frac{M_u}{\phi(d - \frac{a}{2})} = \frac{(234.6)(12)}{(0.9)(21 - \frac{2}{2})} = 156.4 \text{ kips}$$

Calculate new a ,

$$a = \frac{T}{0.85 f'_c b} = \frac{156.4}{(0.85)(3)(30)} = 2 \text{ in.} \quad = 1.6" \text{ assumed}$$

$$A_s = \frac{T}{f_y} = \frac{156.4}{60} = 2.6 \text{ in}^2 \quad \text{at one foot section.}$$

The reinforcement ratio is

$$\rho = \frac{A_s}{bd} = \frac{2.6}{(21)(30)} = 0.0042$$

Minimum reinforcement ratio,

$$\rho_{min} = \frac{200}{f_y} = \frac{200}{60,000} = 0.0033$$

Use 5#7 bars, $A_s = 0.6 \times 5 = 3.0 \text{ in}^2$.

2. Design footing for column A

a. Check punching shear

Assume a 16" depth of footing and #6 bars, the effective depth

$$d = 16" - 2" \text{ (bottom cover)} - 0.75/2 \text{ (one bar size)} = 13.6" = 1.1'$$

Factored footing pressure = $25.3/6.5 = 3.89 \text{ kips/ft}^2$.

The perimeter of punching shear is

$$P = 2 \times (6'' + 12'' + 12.25''/2) + (12'' + 12.25'') = 72.5''$$

The punch shear stress can be calculated as

$$v_u = \frac{[138 - 3.89 \times (1 + 1.03)(0.5 + 1 + 1.03/2)](1000)}{12.3 \times 72.5} = 136.9 \text{ psi}$$

The shear strength of concrete is

$$\phi v_c = 0.85 \times 4 \times 3000 = 186 \text{ psi}$$

O.K.

b. Check direct shear:

The critical section of direct shear is at one effective depth from the face of column.

From Example 3.4, the maximum direction shear is -100.1 kips at inside face of column.

The location of zero shear is at

$$X = 4.5 \times 100.1 / (100.1 + 13.8) = 3.95' \text{ from inside face of the column}$$

The factored shear at one effective depth from the face of the column is

$$V_u = 100.1 \times (4.5 - 20/12) / 4.5 = 63 \text{ kips}$$

Factored shear strength of concrete,

$$\phi V_c = \phi v_c * b * d = (0.85 \times 2 \times 3000) * 6.5 * 12 * 12.3 / 1000 = 89.2 \text{ kips} > 63 \text{ kips O.K.}$$

c. Determine maximum negative reinforcement in longitudinal direction

The maximum negative moment is at zero shear, at 3.95' from inside face of column, or 5.45' from exterior end of footing.

$$M_u = 25.3 * 5.45^2 / 2 - 138 * (0.5 + 3.95) = -238.4 \text{ ft-kips}$$

Use trial method for reinforcement design

Assume $a = 1.4$ ".

$$T = \frac{M_u}{\phi(d - \frac{a}{2})} = \frac{(238.4)(12)}{(0.9)(12.3 - \frac{1.8}{2})} = 278.8 \text{ kips}$$

Calculate new a ,

$$a = \frac{T}{0.85 f'_c b} = \frac{278.8}{(0.85)(3)(6.5)(12)} = 1.4 \text{ in.} = 1.4'' \text{ assumed}$$

$$A_s = \frac{T}{f_y} = \frac{278.8}{60} = 4.64 \text{ in}^2$$

The reinforcement ratio is

$$\rho = \frac{A_s}{bd} = \frac{4.64}{(78)(12.3)} = 0.0048$$

Minimum reinforcement ratio,

$$\rho_{min} = \frac{200}{f_y} = \frac{200}{60,000} = 0.0033$$

Use 9-#7 bars, 5#7 extended from footing strap, 2 #7 in each side of footing,

$$A_s = 0.6 * 9 = 5.4 \text{ in}^2. \text{ Place reinforcement at top face of footing.}$$

d. Determine reinforcement in transverse direction

The distance from face of column to the edge of the footing is

$$l = (6.5 - 1)/2 = 2.75'$$

The factored moment at the face of the column is

$$M_u = (3.89)(2.75)^2/2 = 14.7 \text{ k-ft.} \quad \text{per foot width of footing}$$

Use trial method for reinforcement design

Assume $a = 0.5''$.

$$T = \frac{M_u}{\phi(d - \frac{a}{2})} = \frac{(14.7)(12)}{(0.9)(12.3 - \frac{0.5}{2})} = 16.3 \text{ kips}$$

Calculate new a ,

$$a = \frac{T}{0.85f'_c b} = \frac{16.3}{(0.85)(3)(12)} = 0.53 \text{ in.} \quad \approx 0.5'' \text{ assumed}$$

$$A_s = \frac{T}{f_y} = \frac{16.3}{60} = 0.27 \text{ in}^2 \quad \text{at one foot section.}$$

The reinforcement ratio is

$$\rho = \frac{A_s}{bd} = \frac{0.27}{(12)(12.3)} = 0.0018$$

Minimum reinforcement ratio,

$$\rho_{min} = \frac{200}{f_y} = \frac{200}{60,000} = 0.0033 > \rho_{min} = (4/3) * 0.0018 = 0.0024$$

Use $\rho_{min} = 0.0024$

$$A_s = (0.0024)(6)(12)(12.3) = 2.1 \text{ in}^2.$$

Use 5 #6 bars, $A_s = 0.44 * 5 = 2.2 \text{ in}^2$.

Place reinforcement at bottom face of footing.

2. Design footing for column B

Assume a footing depth of 20'' and #8 bars, the effective depth = 20-3-1=16''

The factored footing pressure = $32.8/8.5=3.86$ ksf

a. Check punching shear

The perimeter of punching shear is

$$P = 4*(12+16)=112''$$

The punch shear stress can be calculated as

$$v_u = \frac{|276 - 3.86 \times (1 + 1.33)^2| (1000)}{16 \times 112} = 142.3 \text{ psi} < 186 \text{ psi} \quad \text{O.K.}$$

b. Check direct shear:

The critical section of direct shear is at one effective depth from the face of column.
From Example 3.4, the maximum direction shear is 128.6 kips at inside face of column.

The factored shear at one effective depth from the face of the column is

$$V_u = 13.8 + (128.6 - 13.8) * (3.5 - 1.33) / 3.5 = 85 \text{ kips}$$

Factored shear strength of concrete,

$$\phi V_c = \phi v_c * b * d = (0.85 \times 2 \times 3000) * 8.5 * 12 * 20.3 / 1000 = 192.5 \text{ kips} > 85 \text{ kips O.K.}$$

c. Determine maximum positive reinforcement in longitudinal direction

$$M_u = 200.9 \text{ ft-kips}$$

Use trail method for reinforcement design

Assume $a = 0.7''$.

$$T = \frac{M_u}{\phi(d - \frac{a}{2})} = \frac{(200.9)(12)}{(0.9)(16 - \frac{0.7}{2})} = 171.2 \text{ kips}$$

Calculate new a ,

$$a = \frac{T}{0.85 f'_c b} = \frac{171.2}{(0.85)(3)(8.5)(12)} = 0.66 \text{ in.} \approx 0.7'' \text{ assumed}$$

$$A_s = \frac{T}{f_s} = \frac{171.2}{60} = 2.9 \text{ in}^2$$

The reinforcement ratio is

$$\rho = \frac{A_s}{bd} = \frac{2.9}{(102)(16)} = 0.0017$$

Minimum reinforcement ratio,

$$\rho_{min} = \frac{200}{f_s} = \frac{200}{60,000} = 0.0033 > \rho_{min} = (4/3) * 0.0017 = 0.0023$$

Use $\rho_{min} = 0.0023$

$$A_s = (0.0023)(8.5)(12)(16) = 3.75 \text{ in}^2.$$

Use 7-#7 bars, $A_s = 0.6 * 7 = 4.2 \text{ in}^2$.

d. Determine reinforcement in transverse direction

The distance from face of column to the edge of the footing is

$$l = (8.5 - 1) / 2 = 3.75'$$

The factored moment at the face of the column is

$$M_u = (3.89)(3.75)^2 / 2 = 27.4 \text{ k-ft. per foot width of footing}$$

Use trail method for reinforcement design

Assume $a = 0.8''$.

$$T = \frac{M_u}{\phi(d - \frac{a}{2})} = \frac{(27.4)(12)}{(0.9)(16 - \frac{0.8}{2})} = 23.4 \text{ kips}$$

Calculate new a ,

$$a = \frac{T}{0.85 f'_c b} = \frac{23.4}{(0.85)(3)(12)} = 0.76 \text{ in.} \approx 0.8'' \text{ assumed}$$

$$A_s = \frac{T}{f_s} = \frac{23.4}{60} = 0.39 \text{ in}^2 \quad \text{at one foot section.}$$

The reinforcement ratio is

$$\rho = \frac{A_s}{bd} = \frac{0.39}{(12)(16)} = 0.002$$

Minimum reinforcement ratio,

$$\rho_{min} = \frac{200}{f_s} = \frac{200}{60,000} = 0.0033 > \rho_{min} = (4/3) * 0.002 = 0.0027$$

Use $\rho_{min} = 0.0024$

$$A_s = (0.0027)(8)(12)(16) = 4.2 \text{ in}^2.$$

Use 8 #7 bars, $A_s = 0.6 * 8 = 4.8 \text{ in}^2$.

4. Designing column dowels.

The bearing capacity of concrete at column base is

$$P_c = (0.7)(0.85)(4)(12)(12) = 342.7 \text{ kips}$$

Which is greater than factored column loads of both A and B.

The minimum dowel area is

$$A_{s,min} = (0.0005)(12)(12) = 0.72 \text{ in}^2$$

Use 4 - #4 dowels $A_s = 0.8 \text{ in}^2$

The footing is shown in below

